

4

3

2

1

THIS DRAWING IS UNPUBLISHED. RELEASED FOR PUBLICATION
 © COPYRIGHT BY TYCO ELECTRONICS CORPORATION. ALL RIGHTS RESERVED.

LOC	DIST	REVISIONS			
P	LTR	DESCRIPTION	DATE	DWN	APVD
DW	/	A1	REVISED (ECR-08-017904)	16JUL08	SC WK

D

D

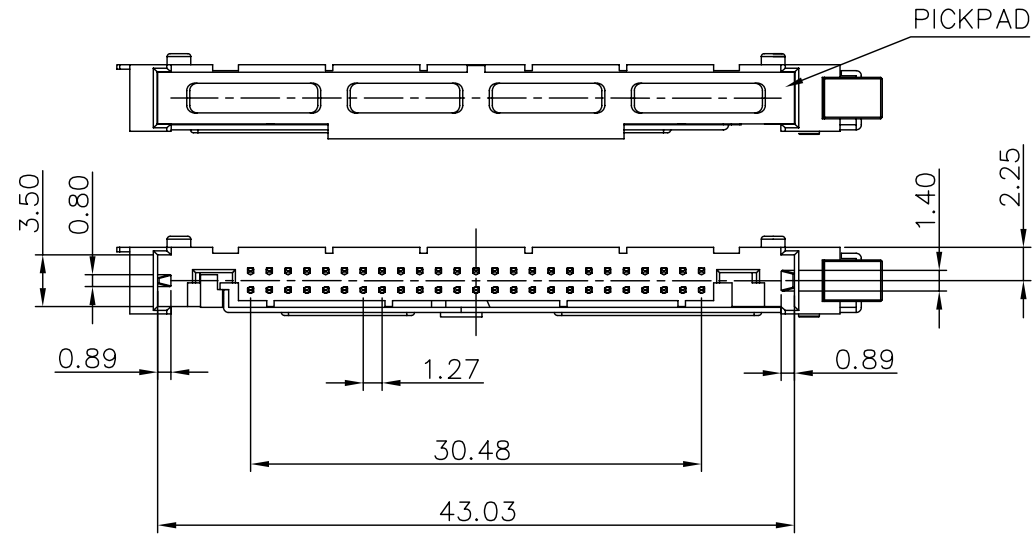

POWER	5.00mm
GENERAL	4.25mm
DETECT	3.50mm
PIN TYPE	INTERFACE DIM. L

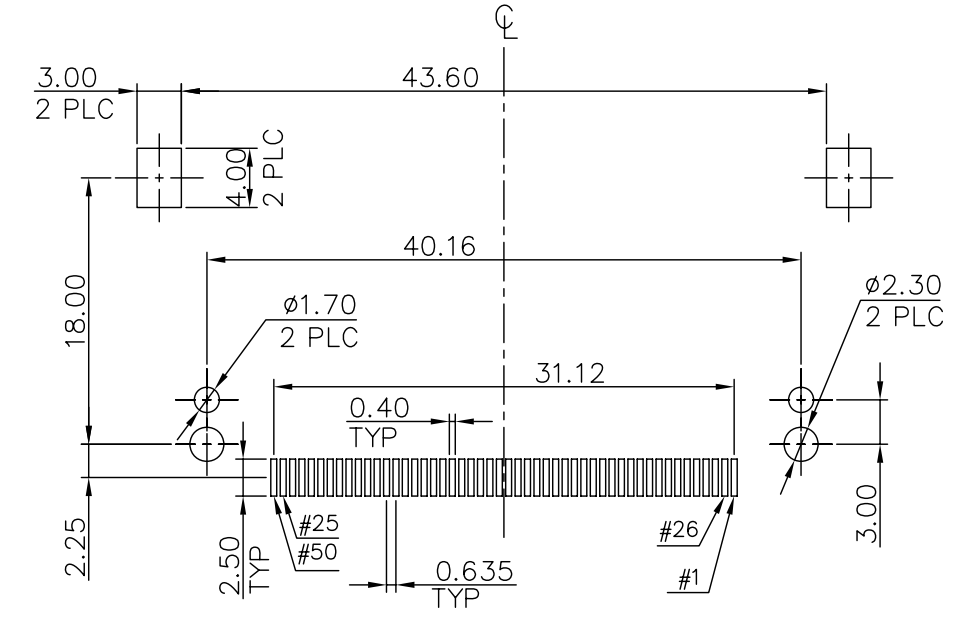

RECOMMENDED PCB LAYOUT
 (TOLERANCE: ±0.05)

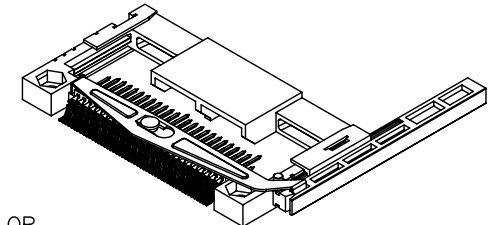

C

C

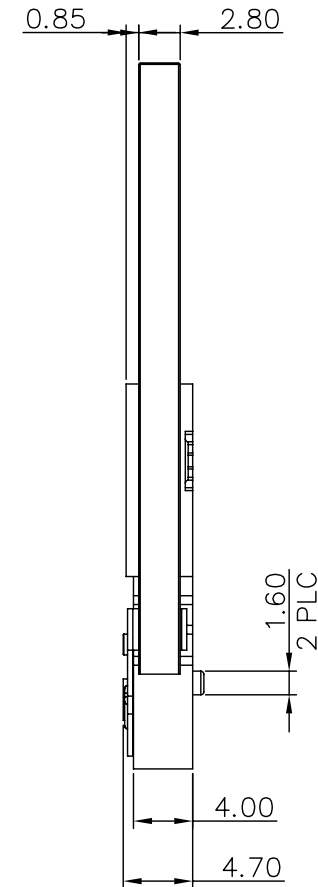
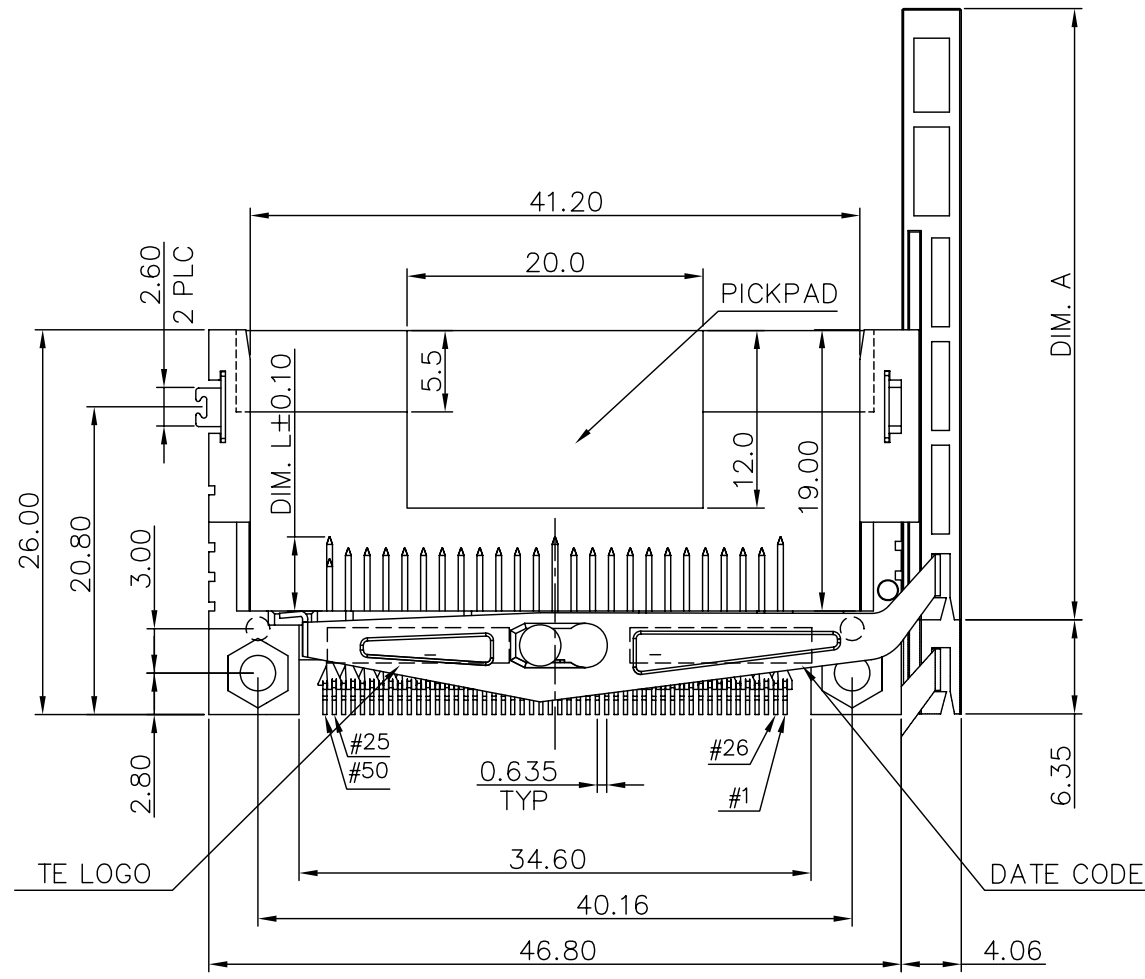

NOTE:

- MATERIAL:
 HOUSING: LCP WITH 30% GF, UL 94V-0, WHITE COLOR.
 EJECTOR: LCP WITH 30% GF, UL 94V-0, BLACK COLOR.
 PICKPAD: LCP WITH 30% GF, UL 94V-0, BLACK COLOR.
 CONTACTS: BRASS.
 BOARDLOCKS: BRASS.
 PIVOT SHELL: STEEL.
- FINISH:
 CONTACTS: 0.381µm [15µ"] GOLD PLATED ON CONTACT AREA,
 2.54µm [100µ"] MIN. MATTE-TIN ON SOLDER TAIL, WITH
 ENTIRE CONTACT UNDERPLATED 1.27µm [50µ"] MIN. NICKEL.
 MOUNT EAR: 2.54µm [100µ"] MIN. TIN PLATED ON SOLDER AREA
 1.27µm [50µ"] MIN. UNDERPLATED ALL OVER.
- REFLOW SOLDER CAPABLE TO 260°C PER TE TEST SPEC.
 109-201, CONDITION B.

34.70	1734909-2
41.30	1734909-1
DIM. A	PART NUMBER

B

B

THIS DRAWING IS A CONTROLLED DOCUMENT.		DWN	S. CHIEN	16JUL2008	Tyco Electronics Corporation Typei, Taiwan	
DIMENSIONS: MM		CHK	S. CHIEN	16JUL2008	NAME	
TOLERANCES UNLESS OTHERWISE SPECIFIED:		APVD	W. KODAMA	16JUL2008	PIN HEADER, 50 POS, SMT, WITH EJECTOR, COMPACT FLASH CARD	
0 PLC ± 0.5		PRODUCT SPEC		SIZE		
1 PLC ± 0.3		108-57134		CAGE CODE	DRAWING NO	RESTRICTED TO
2 PLC ± 0.2		QUALIFICATION TEST REPORT		A300779 C=1734909		
3 PLC ± -		501-57118		WEIGHT		
4 PLC ± -		4.54 GRAMS		CUSTOMER DRAWING		
ANGLES ± -		SCALE		SHEET 1 of 2		
MATERIAL SEE NOTE		FINISH SEE NOTE		REV A1		

A

A

0.12
 ALL CONTACTS AND MOUNT EARS

4

3

2

1

THIS DRAWING IS UNPUBLISHED.

RELEASED FOR PUBLICATION

© COPYRIGHT BY TYCO ELECTRONICS CORPORATION. ALL RIGHTS RESERVED.

LOC		DIST		REVISIONS					
DW				P	LTR	DESCRIPTION	DATE	DWN	APVD
				SEE SHEET 1.					

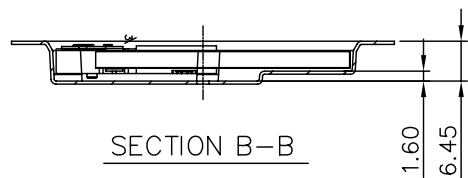
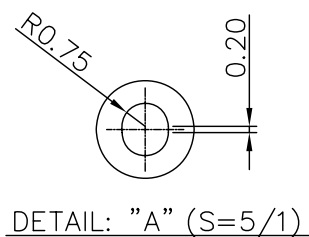
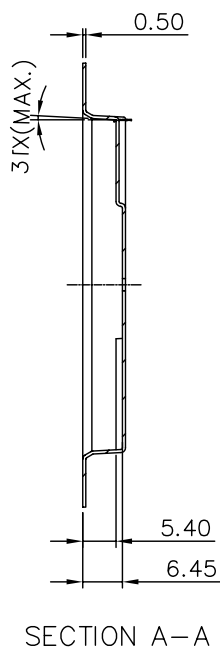
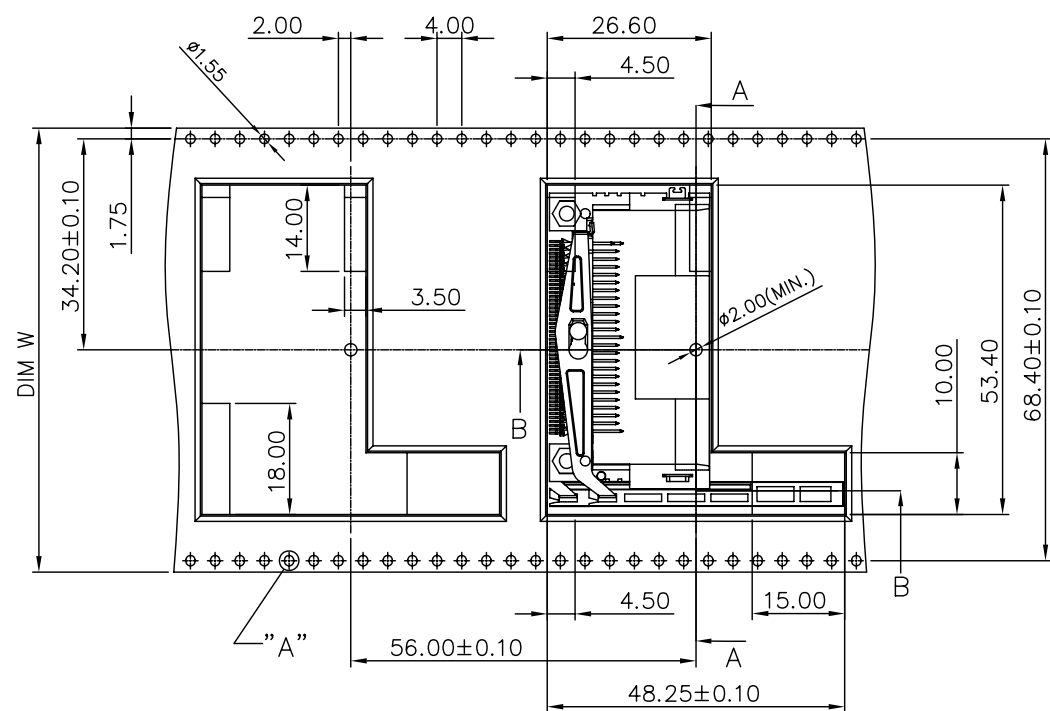
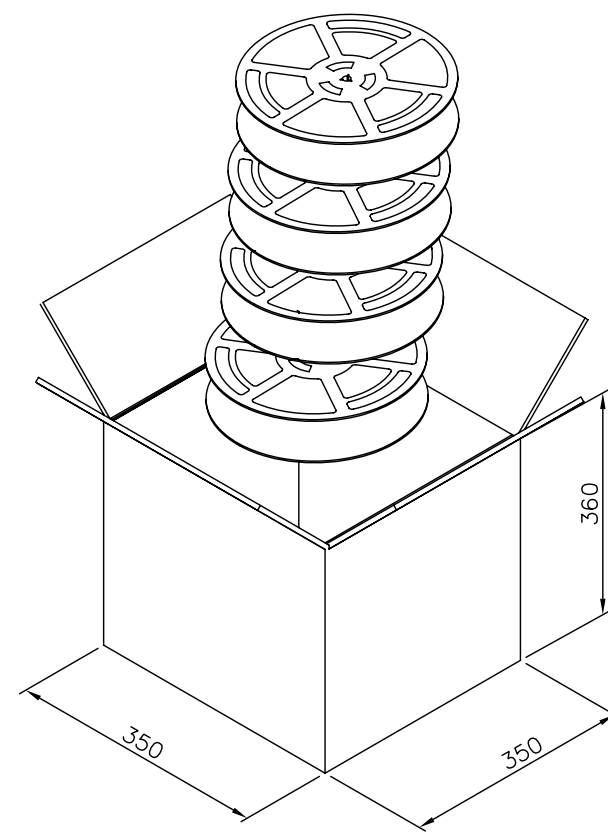
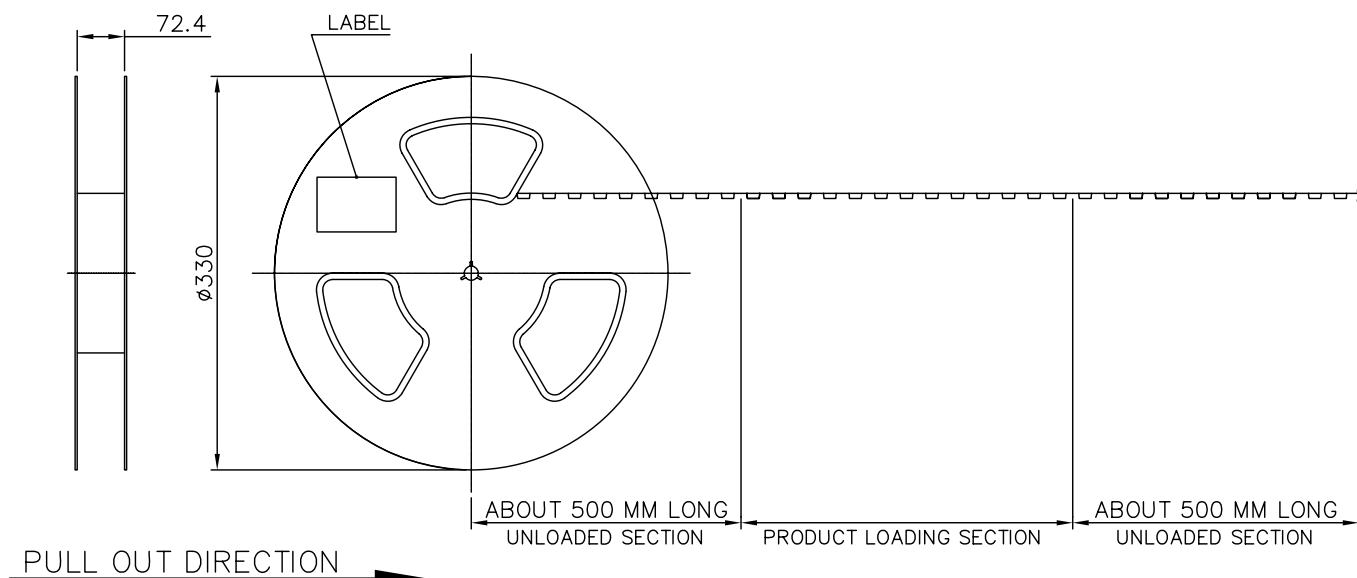

72	110	4	440	6	5.5
DIM W	PCS/TAPE	REELS/CARTON	QUANTITY (PCS)	G/W (Kg)	N/W (Kg)

THIS DRAWING IS A CONTROLLED DOCUMENT.		DWN		Tyco Electronics Corporation	
DIMENSIONS: MM		CHK		Taipei, Taiwan	
TOLERANCES UNLESS OTHERWISE SPECIFIED:		APVD		NAME	
0 PLC ± -		PRODUCT SPEC		PIN HEADER, 50 POS, SMT, WITH EJECTOR, COMPACT FLASH CARD	
1 PLC ± -		APPLICATION SPEC		SIZE	
2 PLC ± -		WEIGHT		CAGE CODE	
3 PLC ± -		CUSTOMER DRAWING		DRAWING NO	
4 PLC ± -		SCALE		RESTRICTED TO	
ANGLES ± -		SHEET		REV	
FINISH		2 OF 2		A1	
MATERIAL		A300779		C=1734909	